

CI/SfB	(29)	(K2)
CAW P10		
Uniclass JP10:L6811		

Product Information

Description

FP220 Service Sleeve is a pipe closer device, comprising of an intumescent material within a stainless steel shell.

Usage / Purpose

FP220 expands when exposed to fire, reinstating the fire performance of compartment walls which have been penetrated by combustible pipes. This product is suitable for either retrofit or for inclusion prior to service installation.

FP220 is required to be installed within a suitably tested substrate or included within other Nullifire tested system solutions. These include, but are not limited to; flexible walls, rigid walls, FB750 Intubatt and FR230 Intucompound.

Tested Combustible Pipe Material Types

PE, HDPE, ABS, San+PVC, PP, PVC-C, UPONOR, DB, MLCP

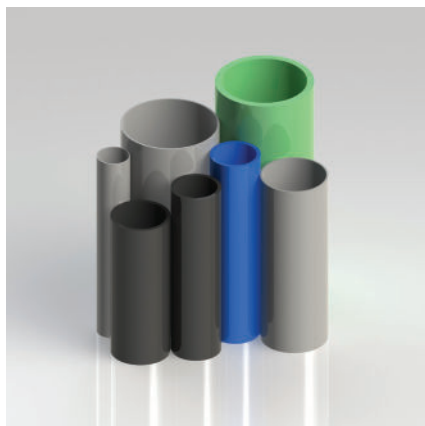

Combustible pipes

Available Sizes

- Circular:

Diameter	Length
ø40	220
ø55	220
ø63	220
ø82	220
ø110	220
ø125	220
ø160	220

- Rectangular:

Height	Width	Depth
204	60	220
220	90	220
110	54	220
225	25	220
300	25	220

Packaging

Supplied individually

Colour

Stainless Steel (Silver)

Availability

Direct from Tremco CPG UK Limited (see details on this TDS)

Usage Guidelines

Always read SDS, pre-application guidance and relevant application detail prior to application. Ensure the latest documents are downloaded prior to every project commencement.

Preparation

- All surfaces must be clean and sound, free from dirt, grease and other contamination.
- Check specification is suitable for service type, substrate and fire rating required.

Installation

- Pull open FP220 and fit around combustible element, and close the sleeve using the retaining clips
- Locate FP220 to required position within the compartment line ensuring equal overhang for each side where possible.
- For gaps up to 20 mm, FP220 may be sealed using FS702 Intumastic. For larger openings, FP220 may be sealed with FB750 Intubatt or FR230 Intucompound.

Important Note

- Do not use around CPVC pipes ; for this specific application, please use FS719 HP Blue for CPVC.
- For more detailed information, service and advice, please call Customer Services on +44 (0)1322 551010.

Nullifire
Smart Protection

FP220

Service Sleeve



Key Benefits Summary

- Up to 2 hours fire resistance - Tested to EN 1366-3.
- Ultra-slim body design ensures easy installation and reduces time on-site.
- No fixings.
- Unaffected by moisture.
- Simple solution for angled pipes.



FP220 Service Sleeve

Typical Details

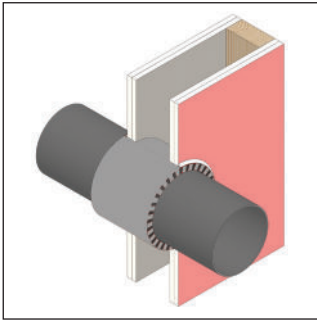

FP220 Service Sleeve pipe penetration in dry lined wall

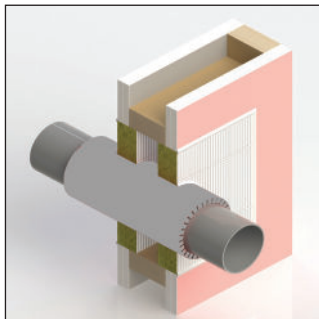

FP220 Service Sleeve pipe penetration with FB750 Batt

Health & Safety Precautions

Safety data sheet must be read and understood before use.

Technical Service

Tremco CPG UK Limited has a team of experienced Technical Sales Representatives who provide assistance in the selection and specification of products. For more detailed information, service and advice, please call Customer Services on +44 (0)1942 251 400

Guarantee / Warranty

Tremco CPG UK Limited products are manufactured to rigid standards of quality. Any product which has been applied (a) in accordance with Tremco CPG UK Limited written instructions and (b) in any application recommended by Tremco CPG UK Limited, but which is proved to be defective, will be replaced free of charge.

No liability can be accepted for the information provided in this leaflet although it is published in good faith and believed to be correct.

Tremco CPG UK Limited reserves the right to alter product specifications without prior notice, in line with Company policy of continuous development and improvement.

Technical Information

Property	Test Method	Result
Composition		Stainless steel shell and a reactive intumescent lining
Application Temperature		Maximum 52°C
Service Temperature Range		Maximum 70°C
Storage	Store in dry ambient conditions up to +35°C	
Shelf Life	Unlimited when stored as recommended	