

CI/SfB	(29)	(K2)
CAW P10		
Uniclass JP10:L6811		

Product Information

Description

FP170 Intucollar comprises of a stainless steel shell and a reactive intumescent lining. FP170 expands when exposed to fire, reinstating the fire performance of compartment walls and floors which have been penetrated by combustible pipes.

FP170 can be used on flexible walls & rigid walls (100 mm or wider) and rigid floors (150 mm or wider).

Usage / Purpose

- FP170 has been tested with combustible pipes (PVC, PE, PP, SanPVC, Bevex, etc.), insulated non-combustible pipes (steel) and network cable bundles (up to 125 mm).
- Typically testing is carried out using (U/U) configuration for maximum coverage to many types of combustible pipe material.

Available Sizes

Collars are available in many sizes to suit the following pipe outside diameters:

- 40 mm
- 55 mm
- 65 mm
- 75 mm
- 82 mm
- 90 mm
- 110 mm
- 125 mm
- 140 mm
- 160 mm
- 200 mm
- 250 mm
- 315 mm
- 355 mm
- 400 mm

Packaging

Above sizes supplied individually. Other sizes subject to minimum order requirements.

Availability

Direct from Tremco CPG UK Limited (see details on this TDS).

Usage Guidelines

Always read SDS, pre-application guidance and relevant application detail prior to application. Ensure the latest documents are downloaded prior to every project commencement.

Necessary Tools

- Drill
- Screwdriver
- Fixings (non-combustible and suited to substrate with a minimum 40 mm embedment)

Preparation

- All surfaces must be clean and sound, free from dirt, grease and other contamination.
- Check specification is suitable for service type, substrate and fire rating required.

Installation

- If required, apply a cold smoke sealant around the pipe to substrate abutment; we recommend FS702 Intumastic or FS709 Intumastic HP
- Position FP170 around the pipe, and against the wall/floor.
- Slide the retaining clip into position and fold back, or secure latch depending on collar type.
- Fix collar into place using non-combustible fixings suitable for substrate (all collar fixing locations require fixings).

Important Information

- Do not use around CPVC pipes ; for this specific application, please use FS719 HP Blue for CPVC.
- Contact Tremco CPG technical for full requirements.

Nullifire
Smart Protection

FPI70

Intucollar Intumescent Pipe Collar

up to
240
mins

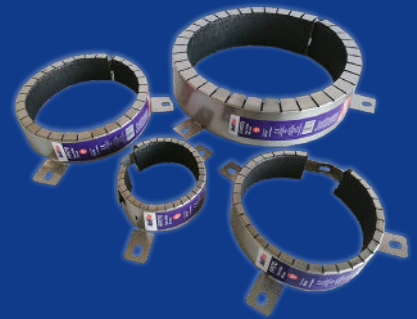

Key Benefits Summary

- Up to 4 hours fire resistance - Tested to EN 1366-3
- Tested for use with combustible pipes, insulated non-combustible pipes, cable bundles and Bevex pipes
- Suitable on flexible & rigid walls, rigid floors
- Easy to install
- Water resistant
- Stainless steel shell

This product is certified to applicable European (EN) standards and UL-EU Mark service requirements.
CERT. N° UL-EU-01113-CPR



CE
ETA 21/0183



FPI70

Intucollar Intumescent Pipe Collar

Nullifire
Smart Protection

Technical Information

Property	Test Method	Result
Composition		Stainless steel shell and a reactive intumescent lining
Durability	EOTATR 024:2009	Y2
Reaction to Fire	EN 13501-1	Class E
Application Temperature		Maximum 52°C
Service Temperature Range		Maximum 70°C
Storage	Store in dry ambient conditions up to +35°C	
Shelf Life	Unlimited when stored as recommended	

Typical Details

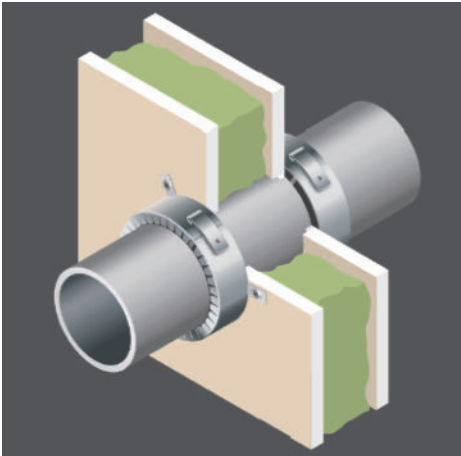

Wall Penetrations: FPI70 should typically be fixed on both sides of any suitable wall construction



Floor Penetrations: FPI70 should typically be fixed to the underside only of any suitable floor construction

Maintenance

No maintenance required after installation. Routine inspection recommended to ensure no damage.

Health & Safety Precautions

Safety data sheet must be read and understood before use.

Technical Service

Tremco CPG UK Limited has a team of experienced Technical Sales Representatives who provide assistance in the selection and specification of products. For more detailed information, service and advice, please call Customer Services on 01942 251400.

Guarantee / Warranty

Tremco CPG UK Limited products are manufactured to rigid standards of quality. Any product which has been applied (a) in accordance with Tremco CPG UK Limited written instructions and (b) in any application recommended by Tremco CPG UK Limited, but which is proved to be defective, will be replaced free of charge.

No liability can be accepted for the information provided in this leaflet although it is published in good faith and believed to be correct.

Tremco CPG UK Limited reserves the right to alter product specifications without prior notice, in line with Company policy of continuous development and improvement.