

CI/SfB	(29)	(K2)
CAW P10		
Uniclass JP10:L68114		

Product Information

Description

FJ400 Intuspan is an extremely compressible, foam based, joint filler. The product is black in colour, and consists of foam layers between high expansion intumescent layers.

It provides a high level of physical movement, and can offer up to 2 hours integrity and insulation, with no adhesive required in most situations.

Usage / Purpose

FJ400 is used to reinstate the performance of fire compartment lines, both walls and floors, where construction joints require a physical movement seal and a specific fire rating. It has been tested in linear joints from 12 mm to 115 mm gap width, and is suitable for use between horizontal and vertical elements.

FJ400 has 60% physical movement capability (compress and return) ; with the correct material set, it offers $\pm 30\%$ movement (30% extension, 30% compression, cold state inhouse tested). It is tolerant of very large movement and is used in areas where standard mastic joints are not suitable, such as large gaps over 35 mm, acoustic isolation joints and areas subject to regular cycles of expansion and contraction or vibration, both in compression and shear, where reliability is vital. In addition, Intuspan is particularly suitable for buildings being designed for earthquake zones or military buildings designed to withstand high ground movement shockwaves.

Colour

Black

Dimensions & Suitability

Actual product sizes (H x W x L) (mm)	Min nominal gap width (mm)	Max nominal gap width (mm)	Max nominal gap width with adhesive (mm)
28 x 25 x 1000	12	25	28
56 x 50 x 1000	23	50	56
87 x 50 x 1000	35	75	87
117 x 100 x 1000	47	100	117

Availability

Direct from Tremco CPG UK Limited (see details on this TDS).

Always read SDS, performance table, pre-application guidance and relevant application detail prior to application. Ensure the latest documents are downloaded prior to every project commencement.

Installation

- Ensure gaps to be filled are the correct specified size and consistent width.
- Ensure fire resistance of FJ400 corresponds or exceeds the requirements of the fire strategy / compartment.
- Check for obstructions to the gap such as ties between steel and masonry and loose mortar. FJ400 may have to be cut around unavoidable obstructions such as wall ties.
- Starting from one end, gently compress FJ400 (using only hand pressure) and insert suitably into required location.
- Consult Performance Data table to ensure correct location requirement is achieved.
- Repeat above process moving along the linear seal, ensuring mating butt joints between lengths of FJ400, until compartment seal is completed.
- It is not normally necessary to use adhesive to retain FJ400. If the gap tolerances are at the maximum height at the FJ400, the FJ400 product is then required to be bonded. To create the bond, use Nullifire FS703 Fire Rated Silicone Sealant (10 mm bead along the length of each substrate abutting face).
- Finally inspect the finished work to ensure compliance with instructions.

Important Information

- FJ400 must be mechanically restrained if used against any non fire rated element (cladding).
- Excessive construction tolerance should be notified to the site manager or engineer.
- In case of airtightness / watertightness requirement, use FS703 to the exposed face, minimum 3 mm thickness.

Storage

Store in dry conditions between -10°C and +70°C.

FJ400

Intuspan Intumescent Joint Filler

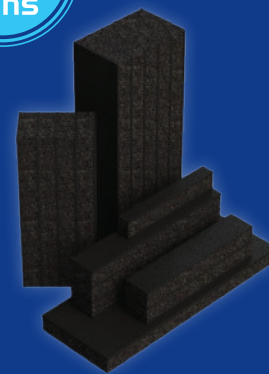

Key Benefits Summary

- Up to 2 hours fire performance - Tested to BS EN 1366-4 and 1366-3
- Ideal for high vibration areas, such as elevator shaft interfaces
- Unaffected by moisture
- Easy to install by hand
- Full dry system when used on its own
- Suits vertical & horizontal joints, and head of walls.



FJ400

Intuspan Intumescent Joint Filler

Nullifire
Smart Protection

Typical Details

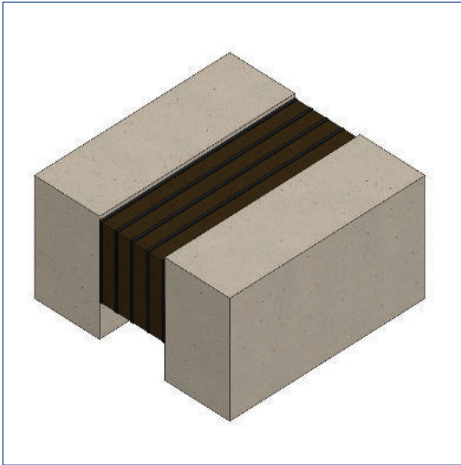

FJ400 in concrete floor

Maximum Continuous Operating Temperature

+80°C (peak +100°C)

Shelf Life

Unlimited when stored as recommended.

Health & Safety Precautions

Safety data sheet must be read and understood before use.

Technical Service

Tremco CPG UK Limited has a team of experienced Technical Sales Representatives who provide assistance in the selection and specification of products. For more detailed information, service and advice, please call Technical Team on +44 (0)1942 251400.

Guarantee / Warranty

Tremco CPG UK Limited products are manufactured to rigid standards of quality. Any product which has been applied (a) in accordance with Tremco CPG UK Limited written instructions and (b) in any application recommended by Tremco CPG UK Limited, but which is proved to be defective, will be replaced free of charge.

No liability can be accepted for the information provided in this leaflet although it is published in good faith and believed to be correct.

Tremco CPG UK Limited reserves the right to alter product specifications without prior notice, in line with Company policy of continuous development and improvement.