

Kingspan **GreenGuard**[®] Car Park Decks

Insulation for car park decks

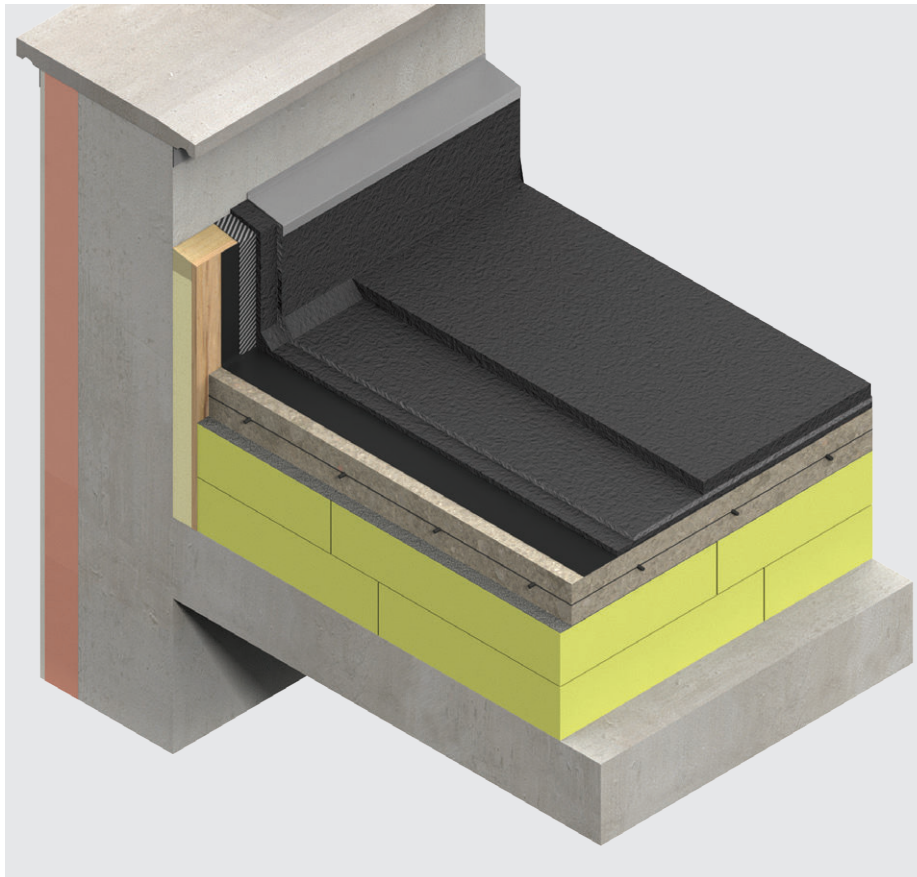

- Rigid extruded polystyrene insulation - thermal conductivities as low as 0.034 W/mK
- High compressive stress withstands vehicle loads
- Resistant to the passage of water vapour
- Easy to handle and install
- Ideal for new build and refurbishment
- Non-deleterious material
- Manufactured with a blowing agent that has zero ODP and low GWP

Typical constructions and U-values

Assumptions

The U-values in the tables that follow have been calculated using the method detailed in BS EN ISO 6946: 2017 (Building components and building elements. Thermal resistance and thermal transmittance. Calculation methods), and using the conventions set out in BR 443 (Conventions for U-value calculations). They U-values in the tables that follow are valid for the constructions shown in the details immediately above each table.

NB For the purposes of these calculations the standard of workmanship has been assumed good, and therefore the correction factor for air gaps has been ignored.

NB The figures quoted are for guidance only. A detailed U-value calculation together with condensation risk analysis should be completed for each project.

NB If your construction is different from those specified, and / or to gain a comprehensive U-value calculation along with a condensation risk analysis for your project, please consult the Kingspan Insulation Technical Service Department for assistance (see rear cover).

U-value table key

Further information on the applicable notional and area weighted average U-values is available in the relevant geographical documentation:

- Approved Documents L to the Building Regulations for England;
- Approved Documents L to the Building Regulations for Wales;
- Technical Handbooks Section 6 to the Building Standards for Scotland;
- Technical Booklets F1 & F2 to the Building Regulations for Northern Ireland; and
- Technical Guidance Document L (Dwellings) and Technical Guidance Document L (Buildings other than Dwellings) to the Building Regulations for the Republic of Ireland.

Parking decks, cars and light commercial vehicles (non HGV)

(Maximum individual wheel load - 1 tonne)

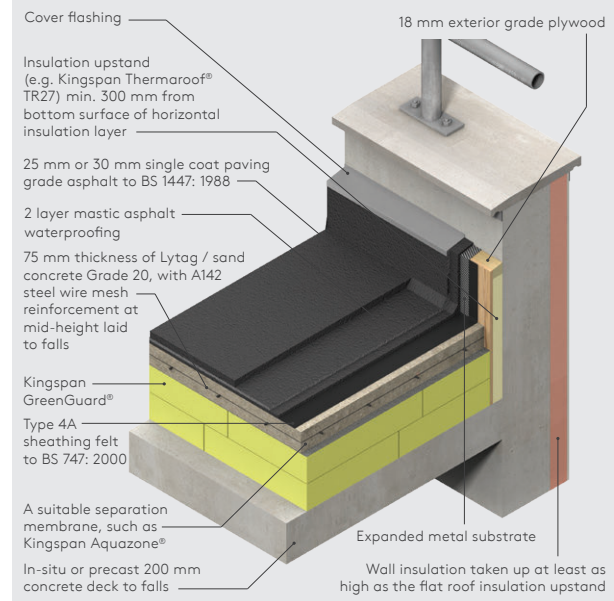

Figure 1

U-values (W/m ² K)	
Insulant thickness (mm)	Kingspan GreenGuard® GG300*
120	-
130 (80 + 50)	0.24
140	0.22
150	0.21
160 (80 + 80)	0.20
170 (120 + 50)	0.18
180 (100 + 80)	0.18
190 (150 + 40)	0.17
200 (100 + 100)	0.16
210 (150 + 60)	0.15
220 (120 + 100)	0.15
230 (150 + 80)	0.14
240 (120 + 120)	0.13
250 (150 + 100)	0.13
270 (150 + 120)	0.12
300 (150 + 150)	0.11
320 (100 + 100 + 120)	0.10
340 (100 + 120 + 120)	0.10
360 (120 + 120 + 120)	0.09

* The above table contains figures for Kingspan GreenGuard® GG300 only. Please consult the Kingspan Insulation Technical Service Department (see rear cover) or U-value Calculator for calculations for other products in the range.

NB Where there are multiple layers of insulation of different thicknesses the thickest insulation board is installed first.

NB Refer to local distributor or Kingspan Insulation price list for current stock and non-stock sizes.

Typical constructions and U-values

Loading bays, service decks and commercial vehicles

(Design should be verified as to suitability for specific wheel loads)

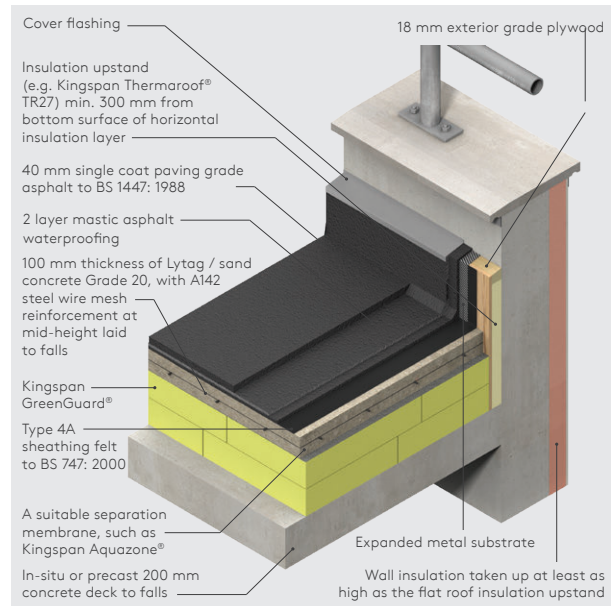

Figure 2

U-values (W/m ² K)	
Insulant thickness (mm)	Kingspan GreenGuard® GG700**
120 (60 + 60)	-
140 (80 + 60)	0.23
160 (80 + 80)	0.21
180 (50 + 50 + 80)	0.18
200 (100 + 100)	0.17
220 (80 + 80 + 60)	0.15
240 (80 + 80 + 80)	0.14

* The above table contains figures for Kingspan GreenGuard® GG700 only. Please consult the Kingspan Insulation Technical Service Department (see rear cover) or U-value Calculator for calculations for other products in the range.

NB Where there are multiple layers of insulation of different thicknesses the thickest insulation board is installed first.

NB Refer to local distributor or Kingspan Insulation price list for current stock and non-stock sizes.

U-values (W/m ² K)	
Insulant thickness (mm)	Kingspan GreenGuard® GG500*
120 (60 + 60)	-
130 (80 + 50)	0.25
140 (80 + 60)	0.23
150 (100 + 50)	0.21
160 (80 + 80)	0.20
180 (100 + 80)	0.18
200 (100 + 100)	0.17
210 (80 + 80 + 50)	0.16
220 (80 + 80 + 60)	0.15
240 (80 + 80 + 80)	0.14
260 (100 + 80 + 80)	0.13
280 (100 + 100 + 80)	0.12
300 (100 + 100 + 100)	0.11

* The above table contains figures for Kingspan GreenGuard® GG500 only. Please consult the Kingspan Insulation Technical Service Department or U-value Calculator (see rear cover) for calculations for other products in the range.

NB Where there are multiple layers of insulation of different thicknesses the thickest insulation board is installed first.

NB Refer to local distributor or Kingspan Insulation price list for current stock and non-stock sizes.

Design considerations

Linear thermal bridging

Basic principles

Linear thermal bridging describes the heat loss / gain that occurs at junctions between elements e.g. where an external wall meets the roof, or at junctions around openings in the building fabric where the thermal insulation layer is discontinuous e.g. sills, jambs and lintels.

Interruptions within the insulation layer by materials with poorer insulating properties can result in a thermal bridge, which in turn can lead to problems of condensation and mould growth, especially if there is a drop in surface temperature.

The heat flow at these junctions and opening locations, over and above that through the adjoining plane elements, is the linear thermal transmittance of the thermal bridge: measured in W/mK; referred to as a 'psi-value'; and expressed as a ' ψ -value'.

The lower the ψ -value, the better the performance. ψ -values are taken into account in the calculation methodologies e.g. the Standard Assessment Procedure (SAP) that are used to assess the operational CO₂ emissions and, where applicable, the fabric energy efficiency of buildings.

ψ -values can comprise either, or a combination of, approved, calculated or assumed values.

Reducing linear thermal bridging

Detailing at junctions to minimise the effects of thermal bridging and the associated risk of condensation or mould growth is important. There are some simple design considerations that can be adopted to help mitigate the risks and to reduce heat losses.

Care is required to ensure continuation of insulation wherever possible between the wall and roof for best thermal performance. Where this is not possible, the roof and wall insulation should be overlapped and ideally, insulation material introduced between.

Parapet detailing can represent a good, low heat loss approach, with insulation continuity maintained using an insulated upstand to reduce cold bridging. A Kingspan Thermarook® TR27 upstand should be used around the perimeter of the roof on the internal façade of parapets to achieve a minimum thermal resistance of 1.10 m²K/W. The upstand should extend a minimum of 150 mm above the roof insulation and achieve a minimum distance of 300 mm between the top of the insulation upstand and the bottom of the horizontal roof insulation. Wall insulation should be carried up into parapets at least as high as the flat roof insulation upstand.

Where possible, insulate around internal rainwater downpipes and other pipes that penetrate the roof if they pass through spaces with a high humidity and if any condensate will damage the structure or internal finishes. Use Kingspan GreenGuard® around the pipe outlet and wrap joints with vapour resistant tape to restrict water vapour from reaching the pipe.

Where guttering is incorporated within a flat roof construction, this should be accounted for within the overall thermal design of the roof via an area-weighted calculation for the whole roof; the risk of localised interstitial condensation from reduced insulation provision at the gutter should be considered.

Where an Internal gutter is formed, where practicable, vertical insulation can be used to reduce thermal bridging.

Responsible sourcing

Kingspan GreenGuard® GG300 produced at Kingspan Insulation's Selby, North Yorkshire manufacturing facility is manufactured under a management system certified to ISO 14001: 2015.

NB The above information is correct at the time of writing. Please confirm at the point of need by visiting the Kingspan Insulation website (see rear cover), from which copies of Kingspan Insulation's certificates can be obtained.

Sustainability & responsibility

Kingspan Insulation has a long-term commitment to sustainability and responsibility: as a manufacturer and supplier of insulation products; as an employer; as a substantial landholder; and as a key member of its neighbouring communities.

A report covering the sustainability and responsibility of Kingspan Insulation Ltd's British operations at its Pembridge, Herefordshire and Selby, North Yorkshire manufacturing facilities is available at www.kingspaninsulation.co.uk/sustainabilityandresponsibility.

Specification clause

Kingspan GreenGuard® should be described in the specification as:-

The roof insulation shall be Kingspan GreenGuard® GG300 / GG500 / GG700 (delete as appropriate) ____mm thick: comprising rigid extruded polystyrene insulation. The product shall be manufactured, with a blowing agent that has zero Ozone Depletion Potential (ODP) and low Global Warming Potential (GWP); under a management system certified to ISO 9001: 2015; and shall be installed in accordance with the instructions issued by Kingspan Insulation Limited.

NBS classifications

The NBS classifications for this product are:
Pr_25_71_63_29 Extruded polystyrene (XPS) boards (Uniclass UK)
J42_415 Extruded polystyrene (XPS) insulation (CAWS - Architecture)

Design considerations

Building Information Modelling (BIM)

BIM objects for Kingspan GreenGuard GG300 can be downloaded using the Kingspan BIM Designer Software Tool available at <https://www.kingspan.com/gb/en-gb/products/insulation-boards/insulation-boards/kingspan-greenguard/kingspan-greenguard-gg300>.

Product selection

The high compressive stress of Kingspan GreenGuard® makes it particularly suitable for use in car park applications where there are likely to be heavy loads.

Consideration must be given to which Kingspan GreenGuard® product is most appropriate for the required application. A table of the key distinguishing features is shown below.

Product	Thermal conductivity (W/mK)	Density (kg/m ³)	Compressive stress (kPa)
Kingspan GreenGuard® GG300	0.034 W/mK (30 - 150 mm)	30	300
Kingspan GreenGuard® GG500	0.034 W/mK (40 - 60 mm) 0.036 W/mK (> 60 mm)	35	500
Kingspan GreenGuard® GG700	0.035 W/mK (50 - 80 mm)	45	700

Design loads & roof structure

Whilst almost any form of roof deck (timber, metal or concrete) can be used with protected membrane roofing systems, the traffic load and additional dead load from the ballast layer invariably limits this type of roof to concrete decks.

Data on specific concentrated loads is contained in BS EN 1991-1-1: 2002 (Eurocode 1. Actions on structures. General actions. Densities, self-weight, imposed loads for buildings) and BS EN 1991-1-7:2006 + A1: 2014 (Eurocode 1. Actions on structures. General actions. Accidental actions). Department of Transport departmental standard BD 21/84 gives typical single wheel loads, depending on the type of vehicle, that act over a 150 mm square or 170 mm diameter contact area. The tyre pressure is taken as 1.1 N/mm², in practice real tyre pressures are lower than this thus giving a lower load intensity.

Vehicle type (weight in tonnes)	Nominal single wheel load (kN)
Cars and vans (< 3)	125
Vehicles generally (3 - 7.5)	50
Vehicles generally (7.5 - 40)	100
Fire engines (up to 60 kN axle load)	30
Fire engines (up to 120 kN axle load)	60

Falls

The fall on a car park deck, constructed using Kingspan GreenGuard®, is normally provided by the screed being laid to falls directed towards the rainwater outlets. The fall should be smooth and steep enough to prevent the formation of rainwater ponds. In order to ensure adequate drainage, BS 6229: 2018 (Flat roofs with continuously supported flexible waterproof coverings. Code of practice) recommends uniform gradients of not less than 1 in 80. However, because of building settlement, it is advisable to design in even greater falls.

Roof waterproofing

Kingspan GreenGuard® is suitable for use with mastic asphalt waterproofing systems. Mastic asphalt waterproofing should be laid, where applicable, in accordance with BS 8218: 1998 (Code of practice for mastic asphalt roofing). Mastic asphalt should always be laid over an isolating layer of loose-laid Type 4A sheathing felt to BS EN 13707: 2013 (Flexible sheets for waterproofing. Reinforced bitumen sheets for roof waterproofing. Definitions and characteristics), itself laid over a layer of Lytag / sand concrete, Grade 20, laid to falls with A142 steel wire mesh reinforcement at mid-height. The exposed face of insulation upstands, at parapets and abutments, must be lined with 18 mm exterior grade plywood, prior to the mastic asphalt waterproofing being laid. The plywood is used as an anchor point for the expanded metal substrate onto which the vertical mastic asphalt is laid.

Water vapour control

There is no requirement for a vapour control layer on car park decks where Kingspan GreenGuard® is overlaid with screed and a mastic asphalt finish. However, this type of roof build up can not be used on high humidity buildings.

Sitework

Insulation boards

- Concrete decks should be clean, dry, without large projections, steps or gaps.
- Start laying the Kingspan GreenGuard® insulation boards from the point of access to the roof.
- Insulation boards should always be loose-laid break-bonded, either with their long edges at right angles to the edge of, or diagonally across the roof, and with joints lightly butted. There should be no gaps at abutments.
- If two or more layers of insulation are required, they should be horizontally offset relative to each other so that, as far as possible, the board joints in any two adjacent layers do not coincide with each other (see Figure 3).

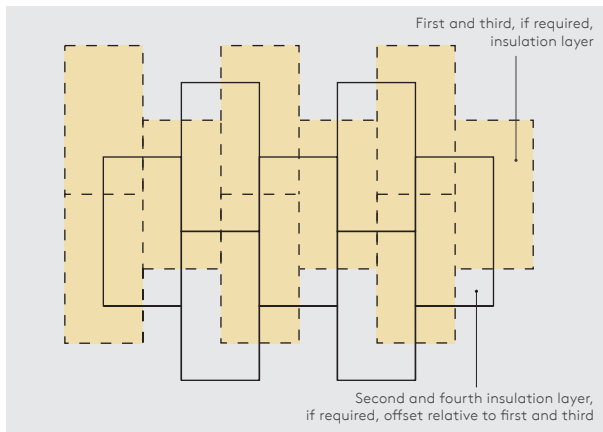

Figure 3 - Offsetting of multiple insulation layers

- Roof-light or ventilator kerbs etc. should always be insulated with Kingspan ThermoRoof® TR27 to the same U-value as the general roof area.
- A Kingspan ThermoRoof® TR27 upstand should be used around the perimeter of the roof on the internal façade of parapets to achieve a minimum thermal resistance of 1.10 m²K/W.
- A minimum distance of 300 mm should be maintained between the top of the insulation upstand and the bottom of the horizontal roof insulation.
- Boards can be laid in any weather but, due to the light weight of the boards, care must be taken in windy conditions.

Screed and mastic asphalt

- A suitable separation membrane, such as Kingspan Aquazone® should be laid over the boards and turned up at abutments.
- Reinforcement can then be fixed and the concrete poured and compacted in accordance with BS EN 1992-1-1: 2004 + A1: 2014 (Eurocode 2: Design of concrete structures. General rules and rules for buildings).
- The mastic asphalt waterproofing is installed in accordance with the membrane manufacturer's instructions, over the whole insulated area including any insulation upstands.

General

Cutting

- Cutting should be carried out either by using a fine toothed saw, a hot wire system or by scoring with a sharp knife and snapping the board over a straight edge.
- Ensure accurate trimming to achieve close-butting joints and continuity of insulation.

Availability

- Kingspan GreenGuard® is available through specialist insulation distributors and selected roofing merchants throughout the UK and Ireland.

Packaging and storage

- Kingspan GreenGuard® may be delivered in packaging bearing alternative product branding.
- The polyethylene packaging of Kingspan Insulation products, which is recyclable, should not be considered adequate for outside protection.
- Ideally, boards should be stored inside a well ventilated building. If, however, outside storage cannot be avoided, then the boards should be stacked clear of the ground and covered with a pale pigmented polythene sheet or weatherproof tarpaulin.
- Kingspan GreenGuard® should not be left in the sun covered by either a transparent or a dark plastic sheet, since in both cases, board temperatures can build up to a level hot enough to appreciably alter their dimensions or warp them.

Health and safety

- Kingspan Insulation products are chemically inert and safe to use.
- A Safety Information Data Sheet for this product is available from the Kingspan Insulation website www.kingspaninsulation.co.uk/safety or www.kingspaninsulation.ie/safety.

Warning - do not stand on or otherwise support your weight on this product unless it is fully supported by a load-bearing surface.

Product details

Composition

Kingspan GreenGuard® GG300, GG500 and GG700 are rigid extruded polystyrene insulants with fibre-free cores. They are manufactured with a blowing agent that has zero Ozone Depletion Potential (ODP) and low Global Warming Potential (GWP) and have a smooth, dense skin on both faces.



Standards and approvals

Kingspan GreenGuard® GG300 produced at Kingspan Insulation's Selby, North Yorkshire manufacturing facility is manufactured to the highest standards under a management system certified to ISO 9001: 2015 (Quality management systems. Requirements), ISO 14001: 2015 (Environmental Management Systems. Requirements), ISO 45001: 2018 (Occupational Health and Safety Management. Requirements with guidance for use) and ISO 50001: 2018 (Energy management systems. Requirements with guidance for use).

Standard dimensions

All products in the Kingspan GreenGuard® range are available in the following standard size:

Nominal dimension	Availability
Length (m)	1.25 and 2.5
Width (m)	0.6
Insulant thickness (mm)	Refer to local distributor or Kingspan Insulation price list for current stock and non-stock sizes.
Edge profile	Straight and rebated

Compressive stress

The compressive stress of Kingspan GreenGuard® is as follows:

Kingspan GreenGuard® GG300 - 300 kPa;

Kingspan GreenGuard® GG500 - 500 kPa; and

Kingspan GreenGuard® GG700 - 700 kPa,

when tested to EN 826: 2013 (Thermal insulating products for building applications. Determination of compression behaviour).

Water vapour resistivity

The products typically achieve a resistivity greater than 400 MN s/gm when tested in accordance with BS EN 12086: 2013 (Thermal insulating products for building applications. Determination of water vapour transmission properties).

Absorption of moisture

Kingspan GreenGuard® is highly resistant to water absorption and the effects of freeze-thaw cyclings.

Durability

If correctly installed, Kingspan GreenGuard® can have an indefinite life. Its durability depends on the supporting structure and the conditions of its use.

Resistance to solvents, fungi & rodents

Kingspan GreenGuard® is resistant to most commonly occurring construction materials such as lime, cement, plaster, anhydrous gypsum, solvent-free bituminous compounds, water-based wood preservatives, as well as alcohols, acids and alkalis. Certain organic materials such as solvent-based wood preservatives, coal tar and derivatives (creosote), paint thinners and common solvents (e.g. acetone, ethyl acetate, petrol, toluene and white spirit) will attack Kingspan GreenGuard®, resulting in softening, shrinkage and possible dissolution, with a consequent loss of performance.

Kingspan GreenGuard® does not provide any food value to vermin and is not normally attractive to them.

Fire performance

Under System 4 AVCP, Kingspan GreenGuard® G300, GG500 and GG700 have a Euroclass rating of F.

Further details on the fire performance of Kingspan Insulation products may be obtained from the Kingspan Insulation Technical Service Department (see rear cover).

Maximum service temperature

Kingspan GreenGuard® should not be brought into direct contact with high temperature heat sources. The maximum service temperature of Kingspan GreenGuard® is 75°C.

Product details

Thermal properties

The λ -values and R-values detailed below are quoted in accordance with BS EN 13164: 2012: + A1: 2015 (Thermal insulation products for buildings. Factory made extruded polystyrene foam (XPS) products. Specification).

Thermal conductivity

The boards achieve a thermal conductivity (λ -value) of Kingspan GreenGuard® GG300 is:

0.034 W/mK (insulant thickness 30 - 150 mm).

Kingspan GreenGuard® GG500 is:

0.034 W/mK (insulant thickness 40 - 60 mm); and

0.036 W/mK (insulant thickness > 60 mm).

Kingspan GreenGuard® GG700 is:

0.035 W/mK (insulant thickness 50 - 80 mm).

Thermal resistance

Thermal resistance (R-value) varies with thickness and is calculated by dividing the thickness of the board (expressed in metres) by its thermal conductivity. The resulting number is rounded down to the nearest 0.05 (m²K/W).

Insulant thickness (mm)	Thermal resistance (m ² K/W)		
	GG300	GG500	GG700
30	0.85	-	-
40	1.15	-	-
50	1.45	1.45	1.40
60	1.75	1.75	1.70
75	2.20	-	-
80	2.35	2.20	2.25
100	2.90	2.75	-
120	3.50	-	-
150	4.40	-	-

NB Multiple layers of insulation are required for higher thermal resistances.

NB Refer to local distributor or Kingspan Insulation price list for current stock and non-stock sizes.

NB Where a hyphen is shown the thickness is not available.

About Kingspan Insulation

Company details

Kingspan Insulation Ltd is part of the Kingspan Group plc., one of Europe's leading construction product manufacturers. The Kingspan Group was formed in the late 1960s and is a publicly quoted group of companies headquartered in Kingscourt, County Cavan, Ireland.

Kingspan Insulation Ltd is a market leading manufacturer of premium and high performance rigid insulation products and insulated systems for building fabric and building services applications.

Products & solutions

Optimum, premium and high performance rigid insulation products for building fabric applications, including roofs, walls and floors.

- Kingspan OPTIM-R® - optimum performance vacuum insulation panel (VIP) systems.
- Kingspan Kooltherm® - premium performance phenolic insulation.
- Kingspan Therma™ - high performance PIR insulation.
- K-Roc® - rock mineral fibre insulation.
- Kingspan GreenGuard® - extruded polystyrene insulation (XPS).
- Kingspan TEK® - structural insulated panels (SIPs).
- Cavity closers - PVC-U extrusions with an insulation core.
- Membranes - for pitched roofs and walls.

Services

We are proud to offer one of the most advanced support services in the construction industry, designed to give fast and accurate advice no matter what your role is. Visit our website to access the following services.

- U-value calculations - free, quick and easy U-value calculations with our U-value Calculator.
- Help and advice on your projects, including stockists, how to guides, regulatory guidance and e-learning.
- Building Information Modelling (BIM) - download BIM objects for our products.
- Tapered roofing service - Kingspan Insulation's tapered roofing systems come with a supporting design service to ensure the most cost-effective solution for a roof is identified.
- CPDs - Kingspan Insulation offer a number of free CPD seminars for architects and specifiers covering a wide range of industry topics. CPDs can be booked or a range of online learning courses can be found online.

Planet Passionate

Planet Passionate is our 10-year group wide global sustainability strategy aims to impact on three big global issues: climate change, circularity and protection of our natural world.

The Planet Passionate strategy is made up of 12 ambitious targets, addressing the impact of Kingspan's business operations and manufacturing on the four key areas of energy, carbon, circularity and water, with commitments by 2030 to include:

- energy: powering 60% of all Kingspan operations directly from renewable energy with a minimum of 20% of this energy generated on manufacturing sites;
- carbon: achieving net zero carbon manufacturing and a 50% reduction in product CO₂ intensity from primary supply partners;
- circularity: upcycling of 1 billion PET bottles per annum into insulation products plus zero company waste to landfill across all sites; and
- water: harvesting 100 million litres of Kingspan's water usage from rainwater.

Contact details

Great Britain

Kingspan Insulation Ltd
Pembroke | Leominster
Herefordshire | HR6 9LA

T: +44 (0) 1544 388 601

E: info@kingspaninsulation.co.uk

www.kingspaninsulation.co.uk

For individual department contact details please visit
www.kingspaninsulation.co.uk/contact

Ireland

Kingspan Insulation Ltd
Castleblayney | County Monaghan

T: +353 (0) 42 979 5000

E: info@kingspaninsulation.ie

www.kingspaninsulation.ie

For individual department contact details please visit
www.kingspaninsulation.ie/contact

To check that you have the latest version of this brochure please visit
www.kingspaninsulation.co.uk/downloads.

To access pre-existing product information or information relating to previously sold/discontinued products please email literature@kingspaninsulation.co.uk.

The information contained in this brochure is believed to be correct at the date of publication. Kingspan Insulation Limited ("Kingspan Insulation") reserves the right to alter or amend the product specifications without notice due to continuous improvement commitments. There may also be relevant changes between publications with regard to legislation, or other developments affecting the accuracy of the information contained in this brochure. Product thicknesses shown in this document should not be taken as being available ex-stock and reference should be made to the current Kingspan Insulation price-list or advice sought from Kingspan Insulation's Customer Service Department. The information, technical details and fixing instructions etc. included in this literature are given in good faith and apply to uses described. Kingspan Insulation does not accept responsibility for issues arising from using products in applications different from those described within this brochure or failure to correctly follow the information or instructions as described within this brochure. Recommendations for use should be verified with a suitable expert or professional for suitability and compliance with actual requirements, specifications and any applicable laws and regulations. For other applications or conditions of use, Kingspan Insulation offers a technical advisory service (see above for contact details), the advice of which should be sought for uses of Kingspan Insulation products that are not specifically described herein. Please check that your copy of this literature is current by contacting the Kingspan Insulation Marketing Department.

© Kingspan, Kingspan GreenGuard, Kooltherm, OPTIM-R, TEK and the Lion Device are Registered Trademarks of the Kingspan Group plc in the UK, Ireland and other countries. All rights reserved.

TM Therma is a Trademark of the Kingspan Group plc.

Kingspan Insulation Ltd is not associated with, and its products have not necessarily been tested by, the GREENGUARD Environmental Institute.

Registered in England & Wales, No. 01882722. Registered Office: Pembroke, Leominster, Herefordshire HR6 9LA UK. VAT GB428602456.

Registered in Ireland, No. 54621. Registered Office: Bree Industrial Estate, Castleblayney, Co. Monaghan, Ireland. VAT IE45750691.

